

Modular Cooking Range Line
thermaline 90 - 600 mm Passthrough
base, 2 doors, GN conform, 2 Sides (H2)
- H=450

ITEM # _____

MODEL # _____

NAME # _____

SIS # _____

AIA # _____



589197 (MC2DCCFOOO)

Passthrough base, with 2
doors, two-side operated,
GN - H2

Short Form Specification

Item No. _____

600 mm wide passthrough base compartment with 2 doors, to store pots, pans, sheet pans, etc. with hygienic design and round edges. Unit constructed according to DIN 18860_2 with 70 mm recessed plinth. Internal frame for heavy duty sturdiness in 2 mm and 3 mm in 1.4301 (AISI 304). 2 mm top in 1.4301 (AISI 304). Flat surface construction, easily cleanable. THERMODUL connection system enables seamless worktop when units are connected and avoids soil penetrating. Open storage space in the base accepts GN 1/1 containers.

IPX5 water resistant certification.

Configuration: Two-side operated freestanding base, hygienic class H2.

Main Features

- All major components may be easily accessed from the front.
- THERMODUL connection system creates a seamless work top when units are connected to each other thus avoiding soil penetrating vital components and facilitating the removal of units in case of replacement or service.
- Unit constructed according to DIN 18860_2 with 70 mm recessed plinth.

Construction

- IPX5 water resistance certification.
- Hygienic design of the open base compartment with large round edges.
- 2 mm top in 1.4301 (AISI 304).
- Flat surface construction with minimal hidden areas to easily clean all surfaces
- Storage space in the base of the appliance that can accept GN1/1 containers.
- Internal frame for heavy duty sturdiness in stainless steel.

APPROVAL: _____

Front

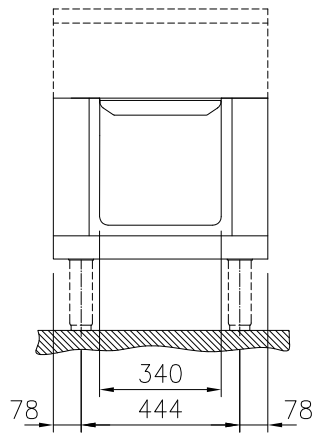

Side

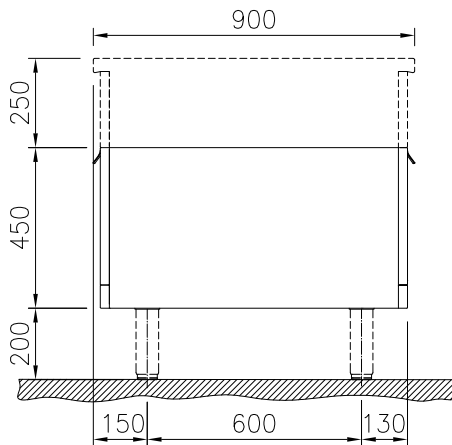

Top

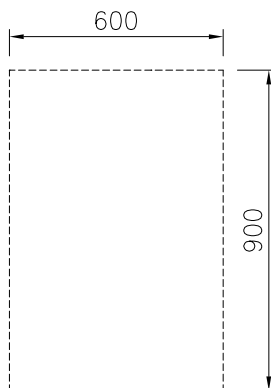
Key Information:

External dimensions, Width:	
589197 (MC2DCCFOOO)	600 mm
External dimensions, Depth:	900 mm
External dimensions, Height:	450 mm
Cupboard Cavity Dimensions (width):	340 mm
Cupboard Cavity Dimensions (height):	330 mm
Cupboard Cavity Dimensions (depth):	810 mm
Net weight:	28 kg

Optional Accessories

- Stainless steel side panel, 900x700mm, freestanding PNC 912512
- Stainless steel front kicking strip, 600mm width PNC 912632
- Stainless steel side kicking strip left and right, freestanding, 900mm width PNC 912657
- Stainless steel plinth, freestanding, 600mm width PNC 912956
- SHELF FOR TL90,2S, CUPBOARD WIDTH=340 PNC 913236
- - NOT TRANSLATED - PNC 913260
- - NOT TRANSLATED - PNC 913280
- STAINLESS STEEL DIVIDING PANEL 900X700MM LEFT/RIGHT PNC 913672
- STAINLESS STEEL SIDE COVER PANEL, FLUSH 900X700MM LEFT/RIGHT PNC 913688